

*) To be used with outboard bearing only

Not all variances of ordering codes can be offered. Please check available part numbers first. For not yet implemented part numbers or special requests please contact Parker Hannifin.

1) Only coded for the last section.

Ordering code

**Heavy-duty aluminium Pumps and Motors
Series PGP, PGM 511**

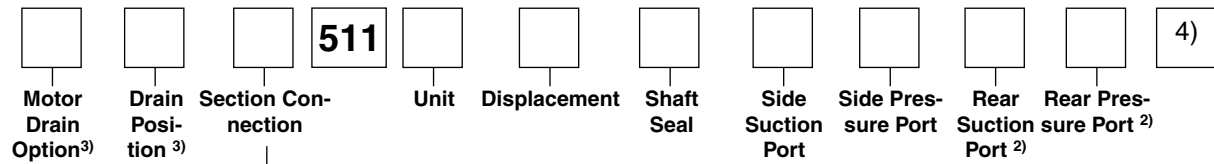

Code	Section Connection
S	Separate inlets
C	Common inlets

Code	Drain Position
2	Drain on bottom
3	Drain on top
4	Rear drain
5	Drain right view on drive shaft
6	Drain left view on drive shaft

Code	Motor Drain Option
B1	no drain
A ²⁾	7/16-20 UNF thread
C	9/16-18 UNF thread
G	1/4 BSP thread
N ²⁾	M10x1 metric thread
P ²⁾	M12x1.5 metric thread

2) Non standard, on request only

Code	Flange
D3	71.4x96.0 - Ø36.47 rectangular
D4	72.0x100.0 - Ø80 rectangular
H2	106.4 - Ø82.55 SAE "A" 2 bolt flange
H3	146.1 - Ø101.6 SAE "B" 2 bolt flange
Q1 ²⁾	60.0x60.0 - Ø52.0 w/o seal ,O' thru bolt flange
Q2	60.0x60.0 - Ø50.0 w. seal ,O' thru bolt flange
Q3 ²⁾	60.0x60.0 - Ø52.0 w/o seal ,O' thru bolt flange
Q4	60.0x60.0 - Ø50.0 w. seal ,O', thru bolt flange
F4	72.0x100.0 - Ø80.0 rect., w. OBB and cont. drive shaft
C3	80x80 - Ø80.0 4 bolt flange

2) Non standard, on request only

Code	Port Options	Code	Port Options
B1	No ports	L1*	13 mm-Ø30 mm-M6 diamond
D2 ²⁾	9/16 - 18 UNF thread	L2*	19 mm-Ø40 mm-M8 diamond
D3 ²⁾	3/4 - 16 UNF thread	N1 ²⁾ *	1/2"-5/16-18UNC SAE Split Flange
D4 ²⁾	7/8 - 14 UNF thread	N2 ²⁾ *	3/4"-3/8-16UNC SAE Split Flange
D5 ²⁾	1 1/16 - 12 UN thread	N3 ²⁾ *	1"-3/8-16UNC SAE Split Flange
D6 ²⁾ *	1 5/16 - 12 UN thread	N4 ²⁾ *	1 1/4"-7/16-14UNC SAE Split Flange
D7 ²⁾ *	1 5/8 - 12 UN thread	P1*	12.7 mm - M8 1/2" Metric Split Flange
E2	3/8 - 19 BSP thread	P2*	19.0 mm - M10 3/4" Metric Split Flange
E3	1/2 - 12 BSP thread	P3*	25.4 mm - M10 1" Metric Split Flange
E4*	5/8 - 14 BSP thread	P4*	31.8 mm - M10 1 1/4" Metric Split Flange
E5*	3/4 - 14 BSP thread		
E6*	1 - 11 BSP thread		
E7*	1 1/4 - 11 BSP thread		
G1 ²⁾	M14x1.5 thread		
G3 ²⁾	M18x1.5 thread		
G4 ²⁾	M22x1.5 thread		
G5 ²⁾ *	M26x1.5 thread		
G7 ²⁾ *	M30x1.5 thread		
J3 ²⁾ *	8 mm - Ø30 mm - M6 square		
J4 ²⁾ *	12 mm - Ø30 mm - M6 square		
J5*	15 mm - Ø35 mm - M6 square		
J6 ²⁾ *	15 mm - Ø40 mm - M8 square		
J7*	20 mm - Ø40 mm - M6 square		
J8*	18 mm - Ø55 mm - M8 square		
J9*	26 mm - Ø55 mm - M8 square		

2) Non standard, on request only

*) Not usable for rear ports

3) Only for motors

4) For further "B" triple unit repeat displacement, shaft seal between sections, side suction port, side pressure port, rear suction port, rear pressure port.

PGP/PGM 511 Specification - Standard Displacements

Pump Displacement	Code	0060	0080	0100	0110	0140	0160	0190	0230	0270	0330
	cm ³ /rev	6.0	8.0	10.0	11.0	14.0	16.0	19.0	23.0	27.0	33.0
Max. Continuous Pressure	bar	250	250	250	250	250	250	250	225	190	155
Minimum Speed @ 0 Inlet & Max. outlet pressure	rpm	500	500	500	500	500	500	500	500	500	500
Maximum Speed @ 0 Inlet & Max. outlet pressure	rpm	3500	3500	3500	3500	3500	3500	3250	2750	2350	2000
Pump Input Power @ Max. Pressure and 1500 rpm	kW	4.5	6.0	7.5	8.3	10.5	12.0	14.3	14.7	14.9	17.3
Dimension "L"	mm	50.1	53.3	56.5	58.0	62.8	65.9	70.6	76.9	83.2	92.6
Approximate Weight ¹⁾	kg	3.40	3.47	3.55	3.57	3.71	3.79	3.91	4.06	4.21	4.45

¹⁾ Single pump with Flange Q1 and Port end cover B1

Distributor Unit PGP 511

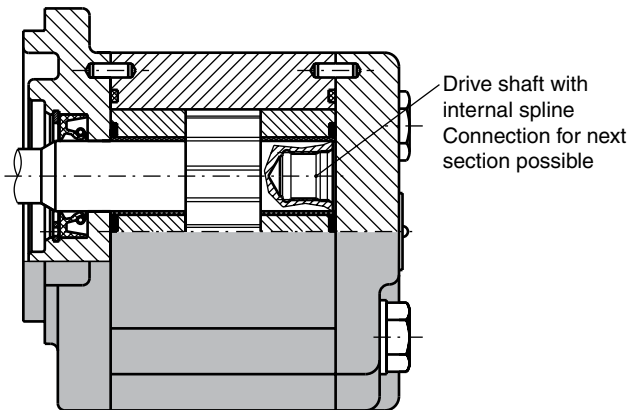

Single Unit PGP/PGM 511

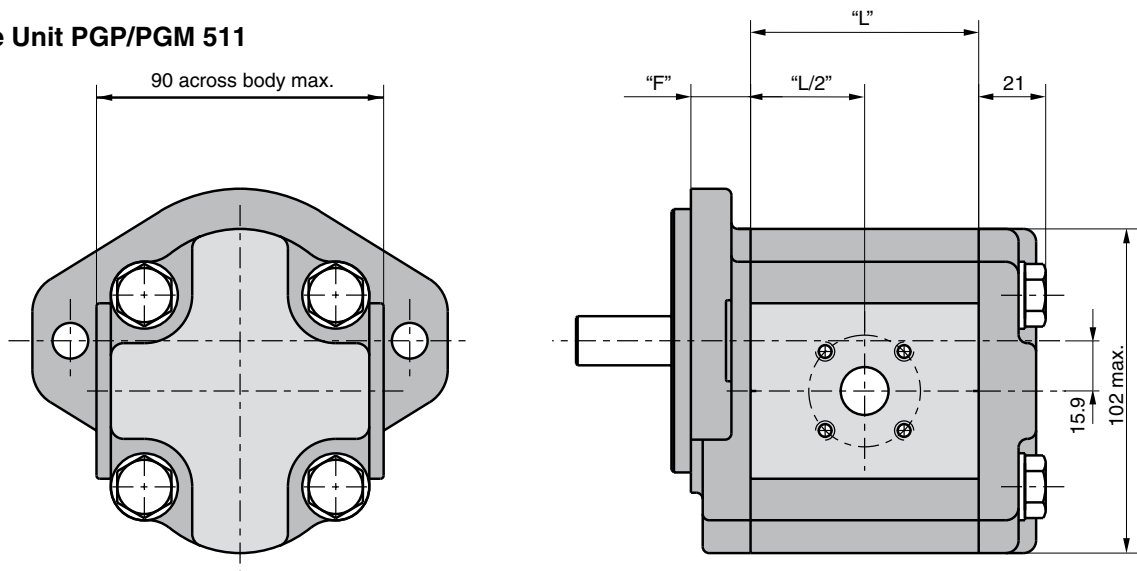

Dimension "L" see table above

Dimension "F" see flanges on pages 31 to 34

Dimension Shafts see pages 38 to 40

Single Unit PGP/PGM 511 with rear ports

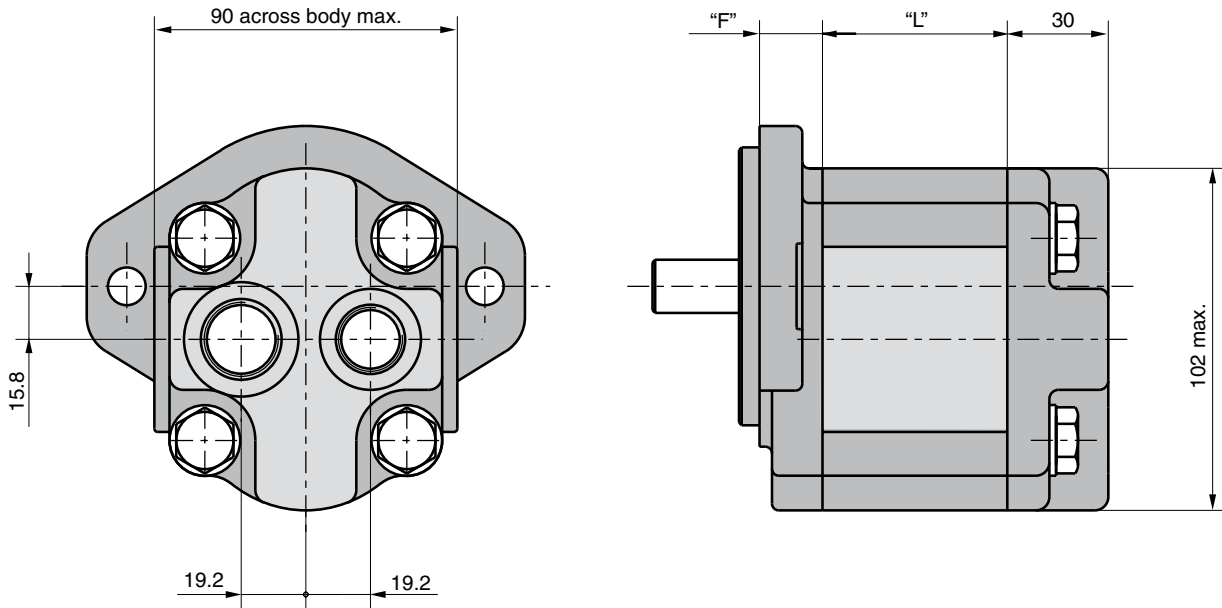

Dimension "L" see table on page 29

Dimension "F" see flanges on pages 31 to 34

Dimension Shafts see pages 38 to 40

Tandem Unit PGP/PGM 511

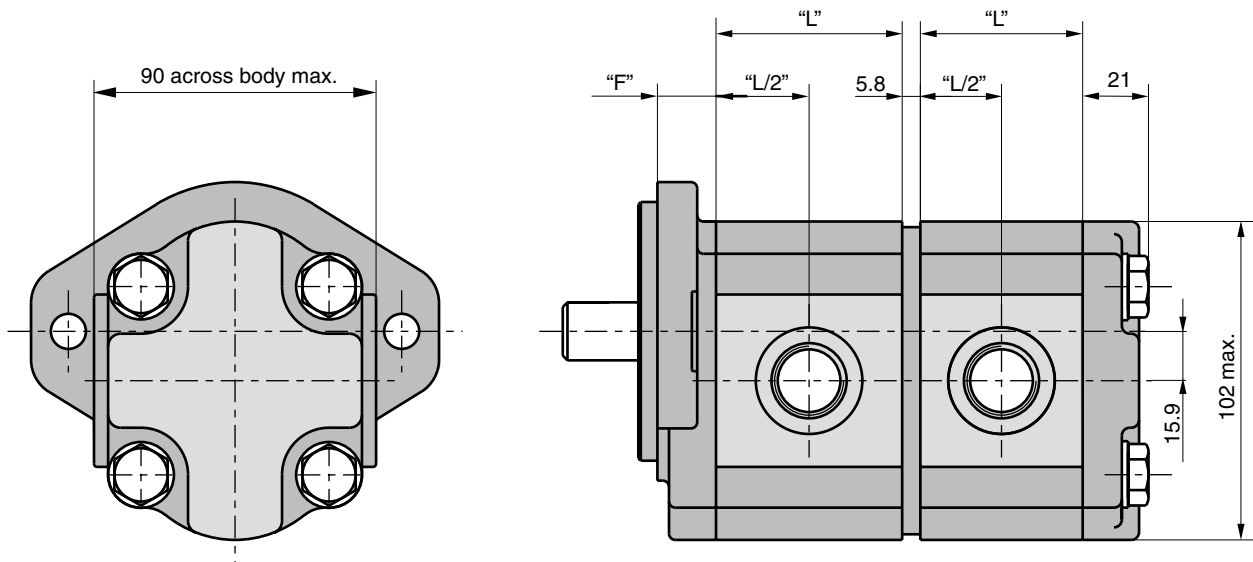

Dimension "L" see table on page 29

Dimension "F" see flanges on pages 31 to 34

Dimension Shafts see pages 38 to 40

PGP/PGM 511 Mounting Flange

Code D3

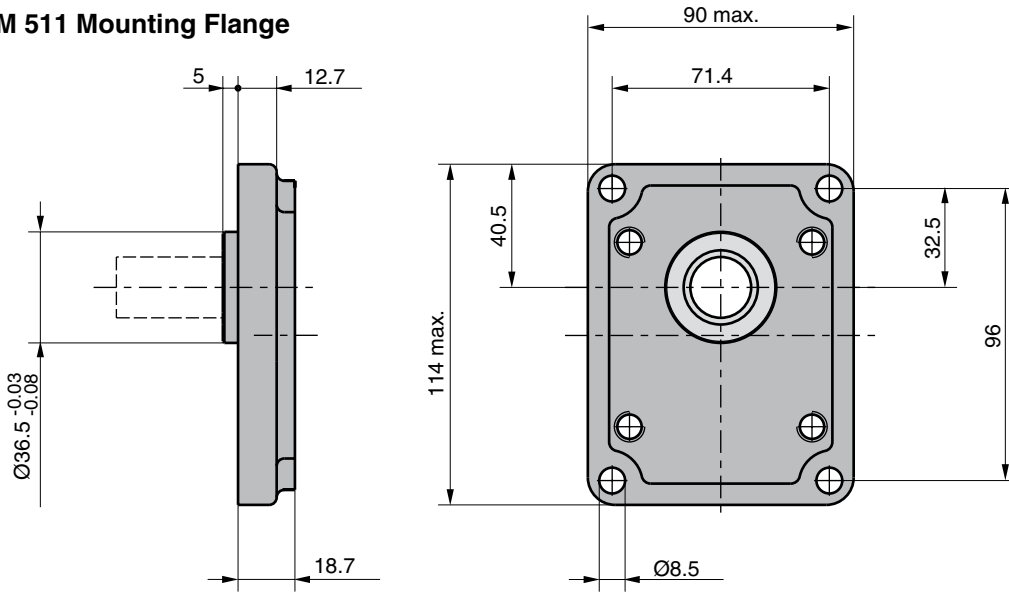

Code D4

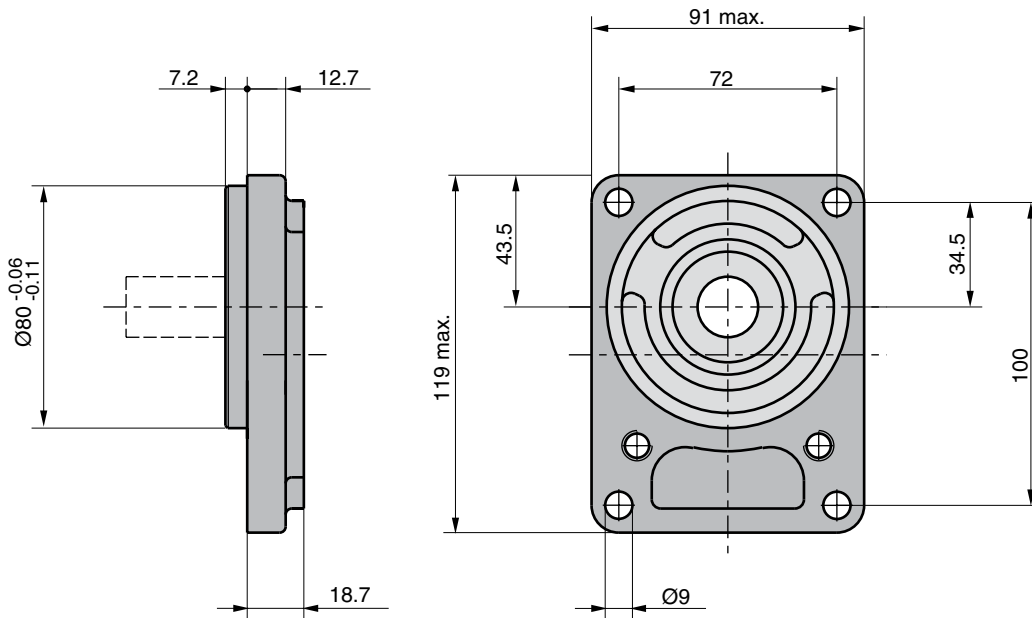

Code H2

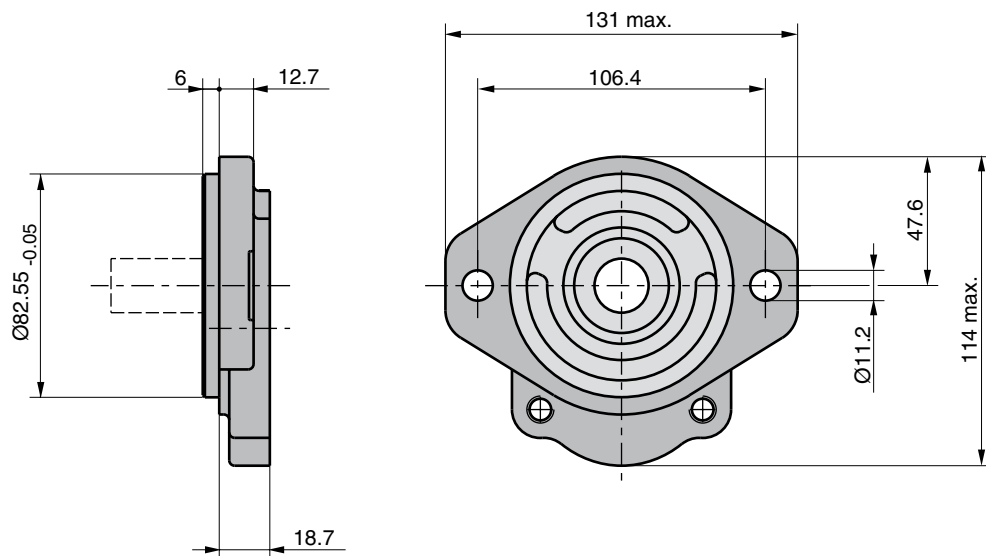

PGP/PGM 511 Mounting Flange

Code H3

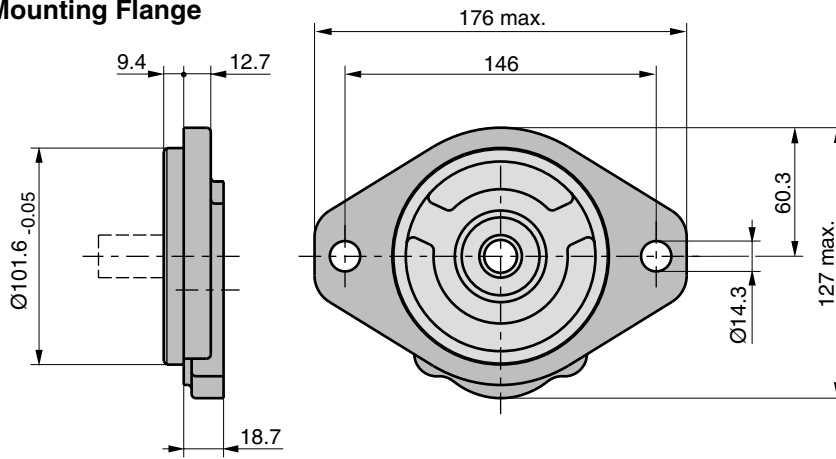

Code Q1

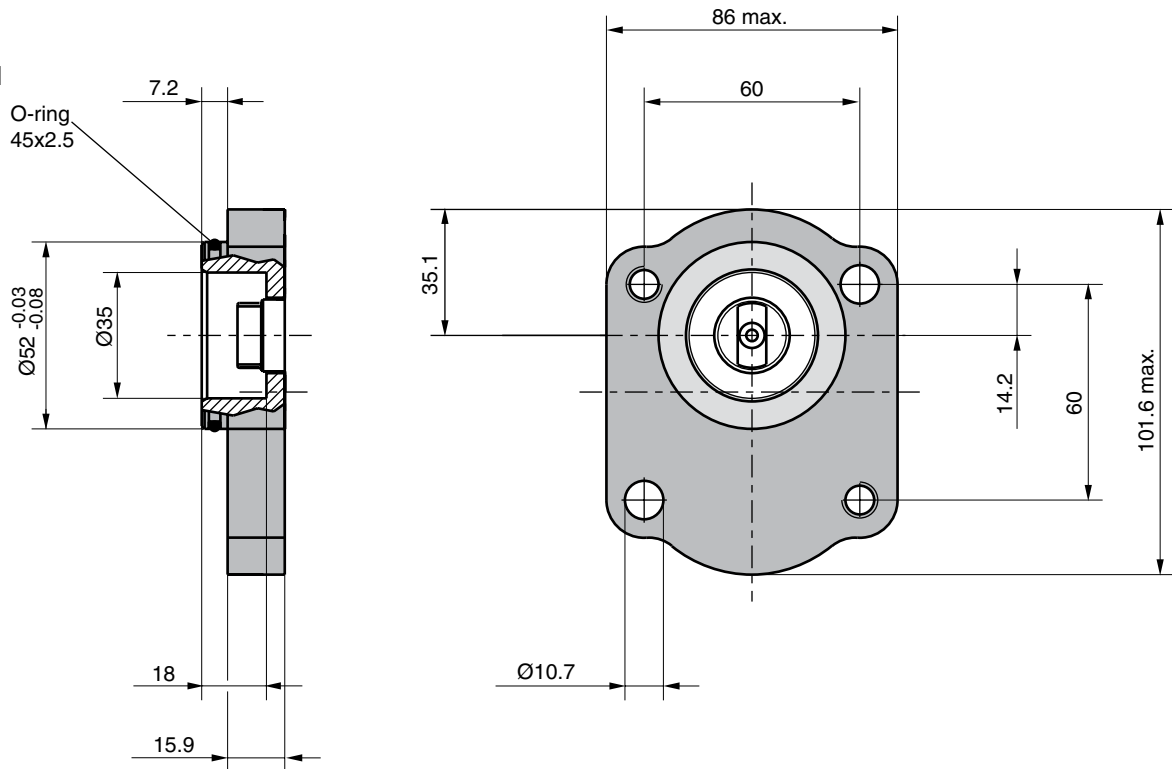

PGP/PGM 511 Mounting Flange

Code Q2

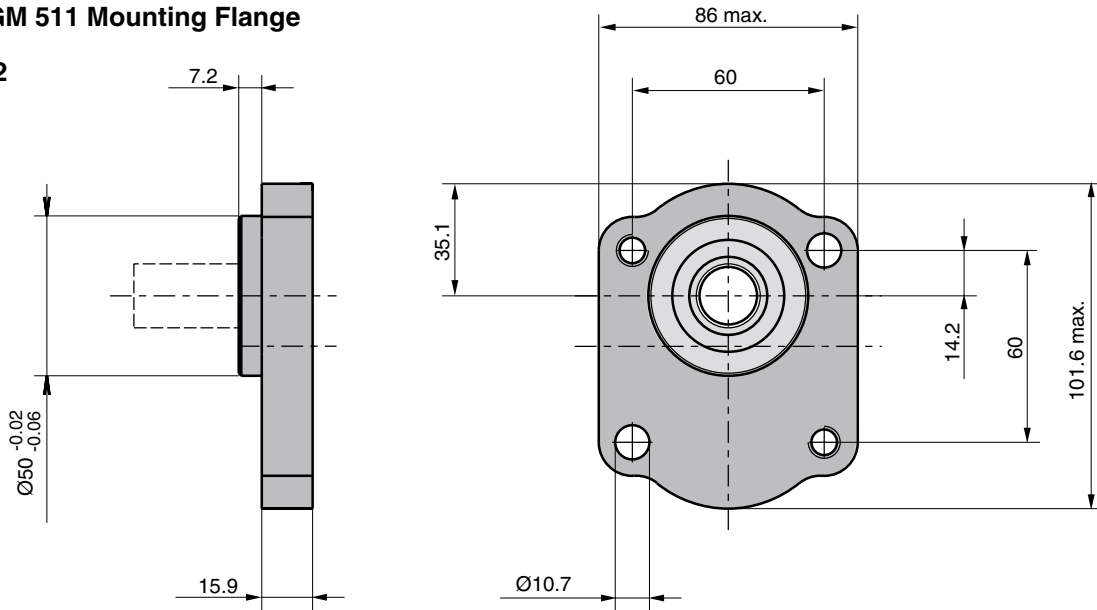

Code Q3

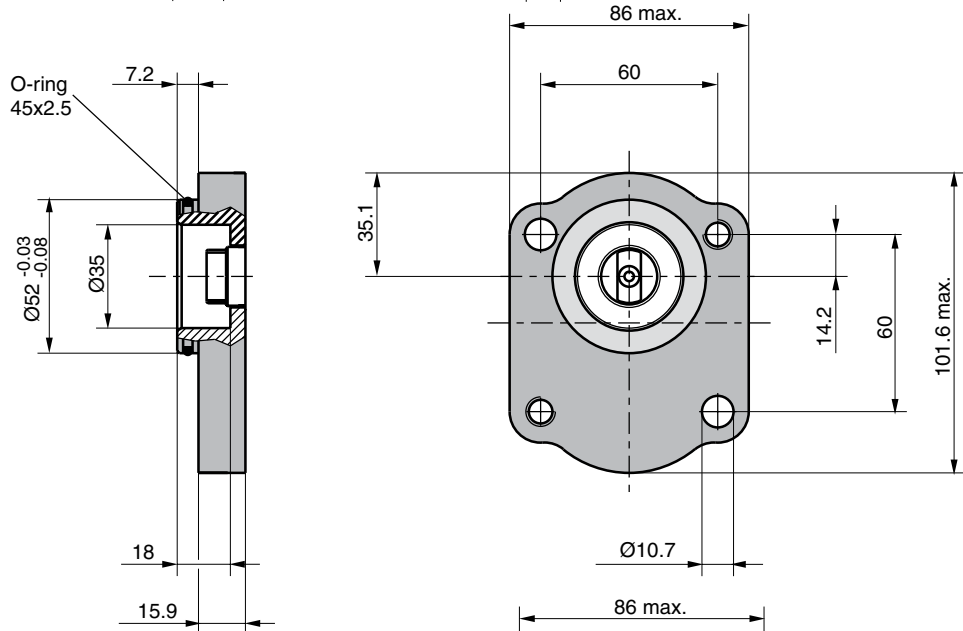

Code Q4

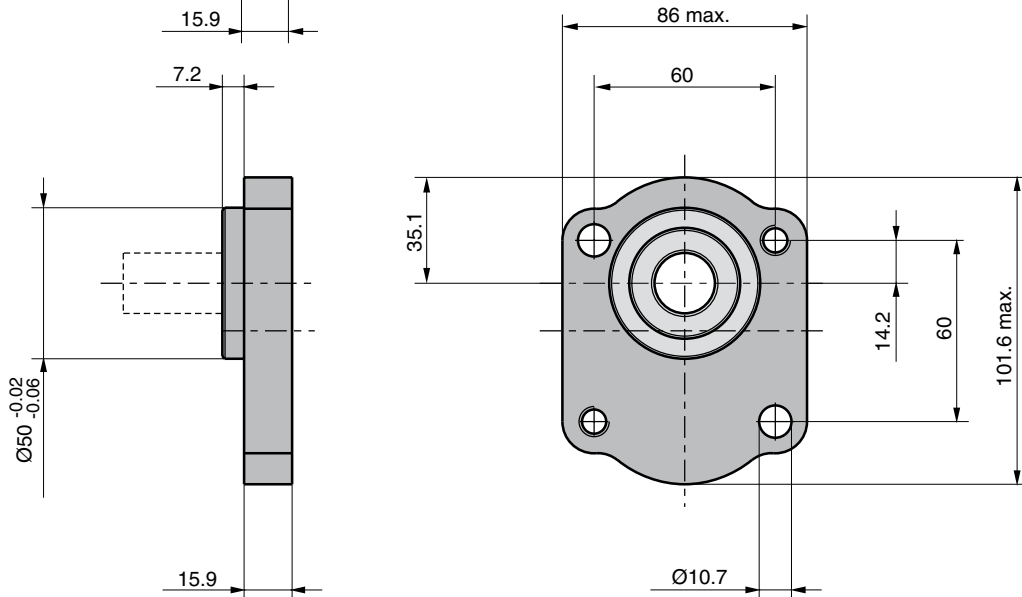

PGP/PGM 511 Mounting Flange

Code F4

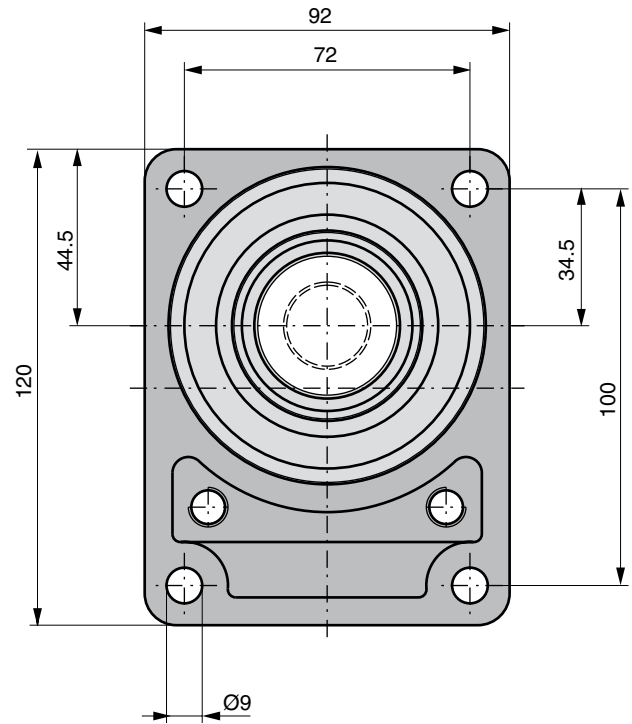
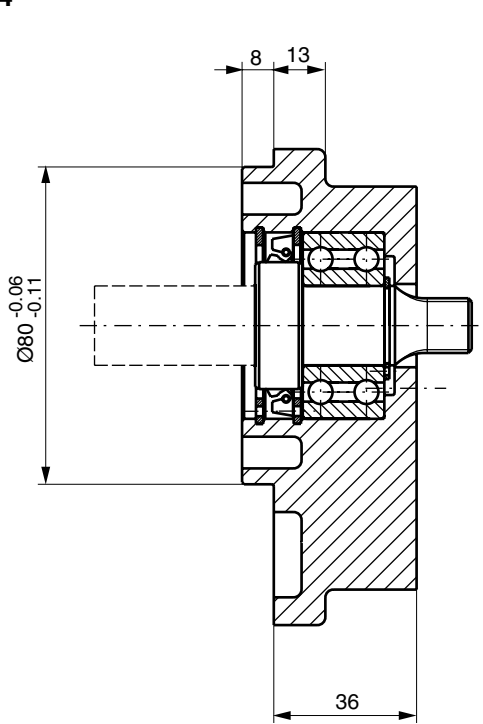

Code C3

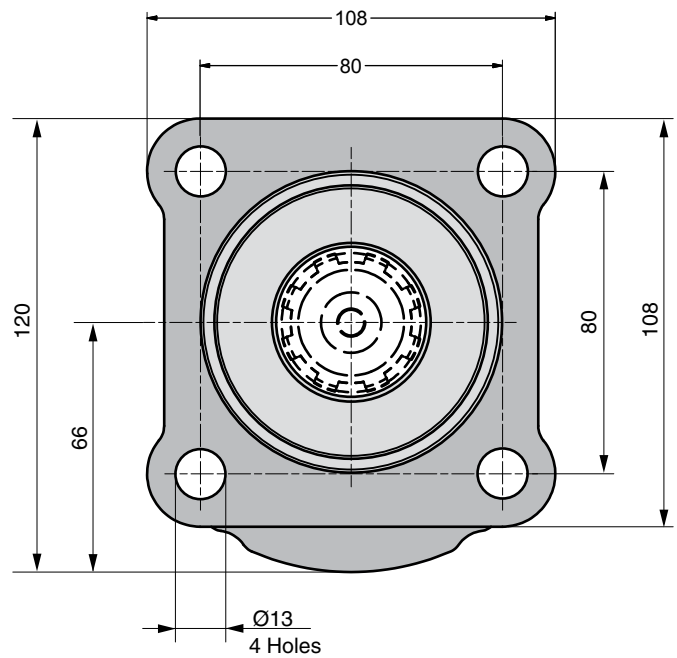
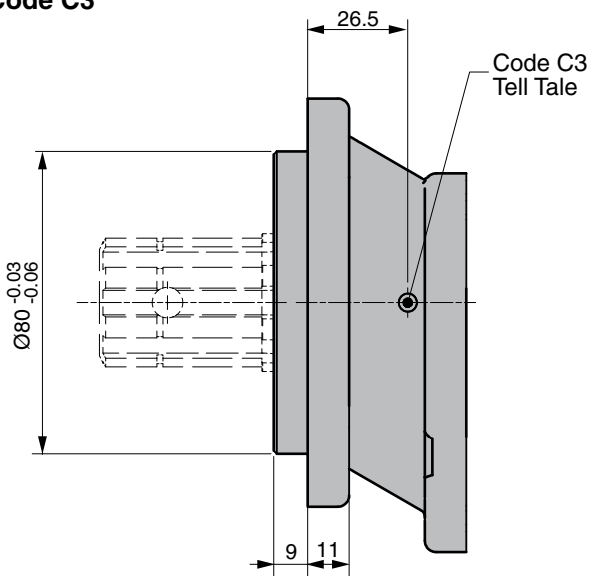

Outboard Bearing PGP-PGM 511

Bearing loads for code F4

Units subject to axial or radial loads, for instance drive with V-belts or gear wheels, must be specified with an outboard bearing.

The diagrams below show the maximum axial or radial loads that can be tolerated referred to a bearing life of $L_H = 1000$ h.

F_r is reduced by 0,7 F_a when axial loading is applied.

Outboard Bearing Code F4

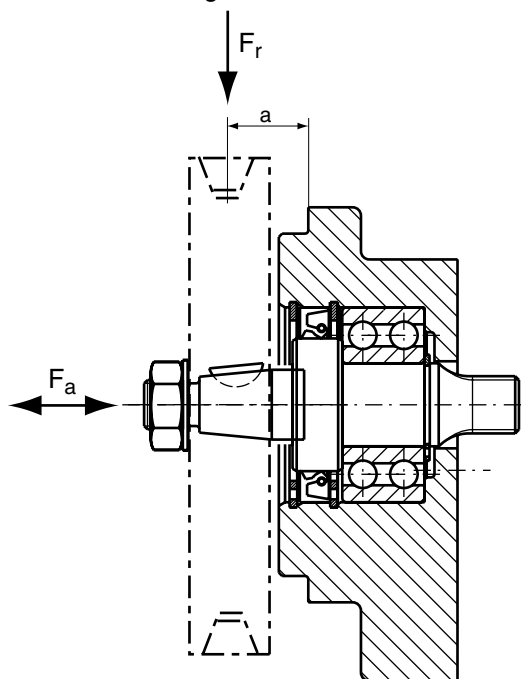

Shaft load for outboard bearings PGP/PGM 511

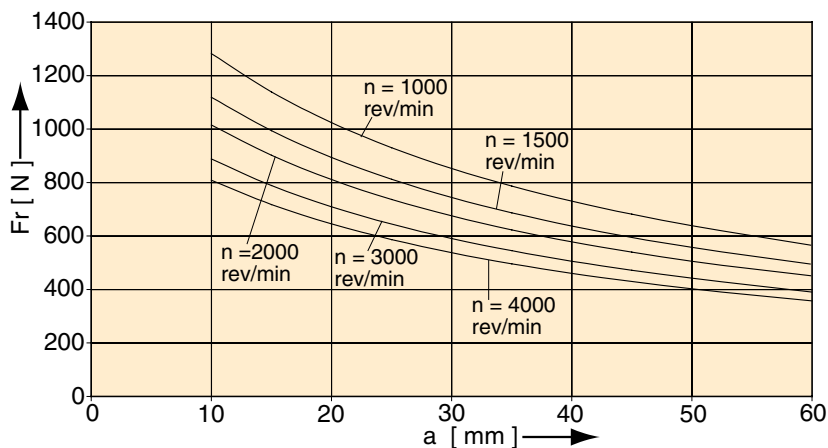

PGP/PGM 511 Porting

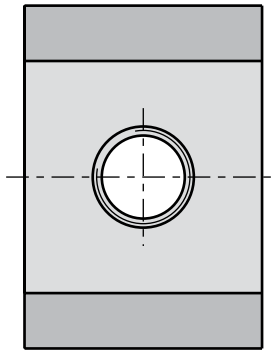

Code E
 British Standard Pipe
Code G
 Metric straight thread

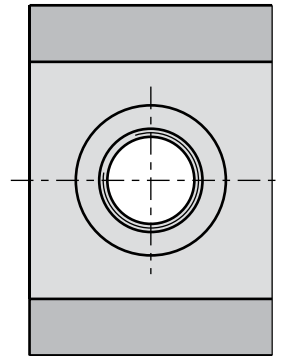
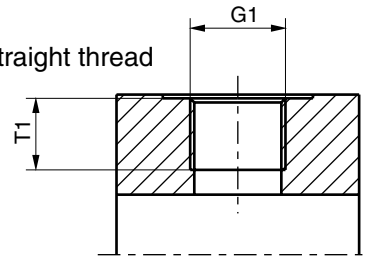

Code D
 SAE straight thread

PGP/PGM 511

Code	G1	T1
	Thread	Dimensions
D2	9/16-18 UNF	12.7
D3	3/4-16 UNF	14.3
D4	7/8-14 UNF	16.7
D5	1 1/16-12 UN	19.0
D6	1 5/8-12 UN	19.0
D7	1 5/8-12 UN	19.0
E2	3/8-19 BSP	12.0
E3	1/2-14 BSP	14.0
E4	5/8-14 BSP	16.3
E5	3/4-16 BSP	16.0
E6	1-11 BSP	18.0
E7	1 1/4-11 BSP	20.0
G1	M 14x1.5	12.0
G3	M 18x1.5	12.0
G4	M 22x1.5	14.0
G5	M 26x1.5	16.0
G7	M 30x1.5	12.0

Code L
 4-Bolt flange

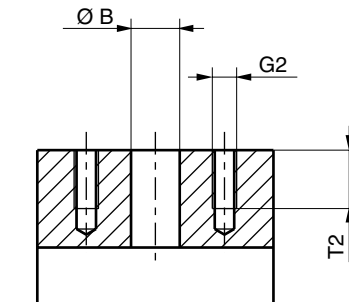
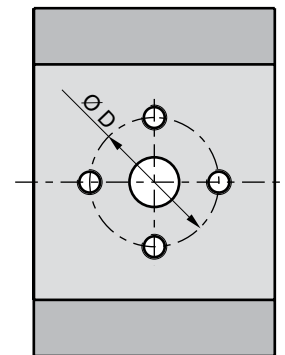

PGP/PGM 511 Porting

Code N
 SAE Split flange

Code P
 SAE Split flange
 metric thread

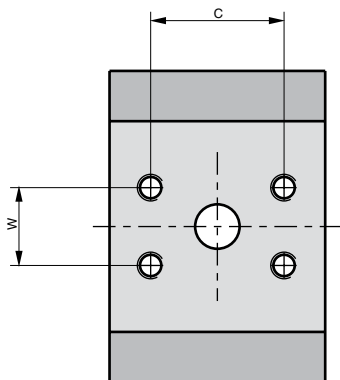

Code J
 European flange

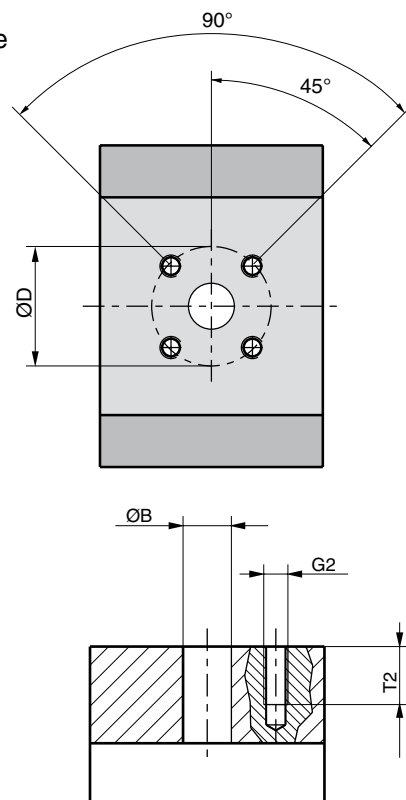

PGP/PGM 511

Code	G2	Ø B	Ø D	S	C	W	T2
	Thread						
J3	M6	8.0	30.0				12.0
J4	M6	12.0	30.0				12.0
J5	M6	15.0	35.0				12.5
J6	M8	15.0	40.0				15.0
J7	M6	20.0	40.0				13.0
J8	M8	18.0	55.0				15.0
J9	M8	26.0	55.0				15.0
K1	5/16-18 UNC	19.0		30.48			15.0
K2	M8	19.0		30.48			15.0
K3	M6	19.0		32.00			13.0
K4	M6	16.0		25.15			13.0
L1	M6	13.0	30.0				13.0
L2	M8	19.0	40.0				15.0
N1	5/16-18 UNC	12.7			38.10	17.48	15.0
N2	3/8-16 UNC	19.0			47.63	22.23	14.0
N3	3/8-16 UNC	25.4			52.37	26.19	20.6
N4	7/16-14 UNC	31.8			58.72	30.17	20.6
P1	M8	12.7			38.10	17.48	15.0
P2	M10	19.0			47.63	22.23	20.6
P3	M10	25.4			52.37	26.19	21.4
P4	M10	31.8			58.72	30.17	20.6

PGP/PGM 511 Drive Shaft

Code A1

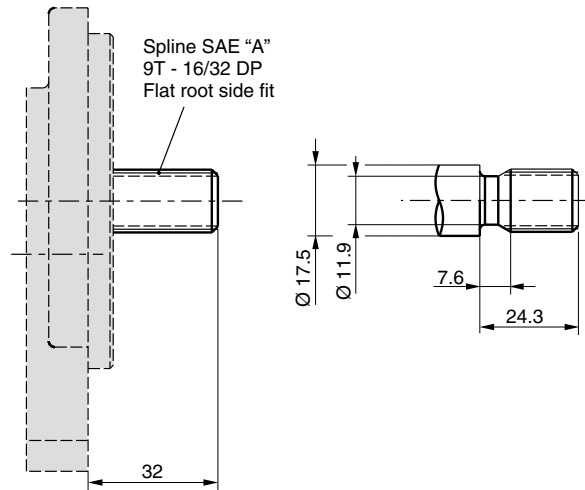

Code C1

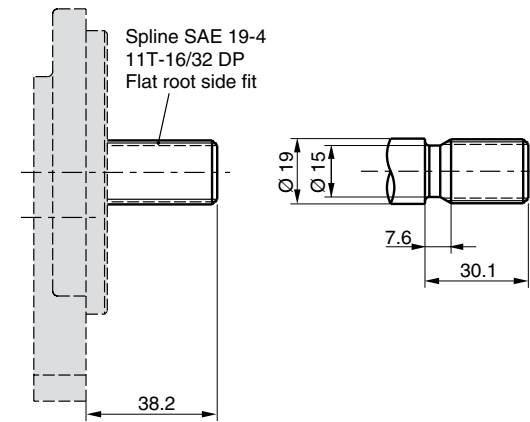

Code K1

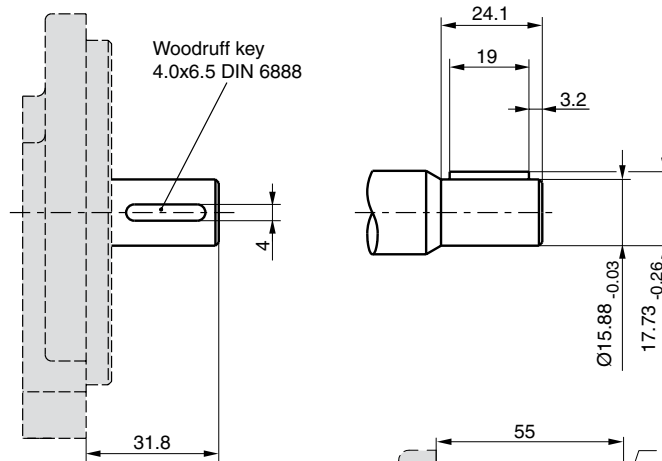

Code F5

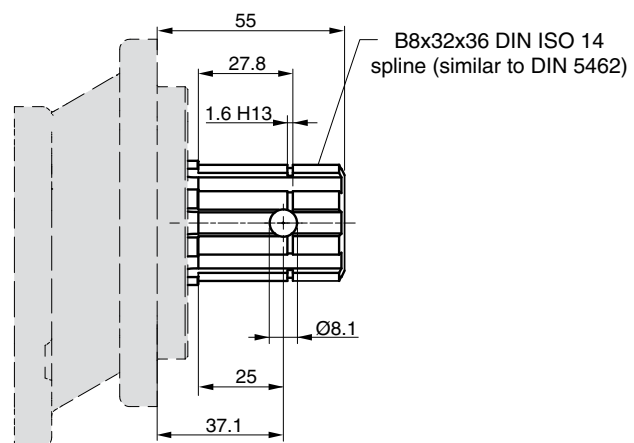

PGP/PGM 511 Drive Shaft

Code L6

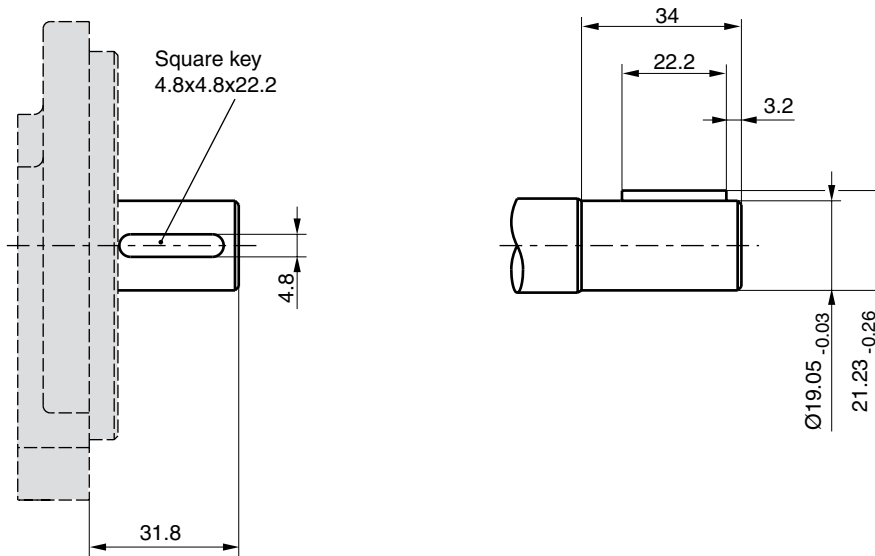

Code S1

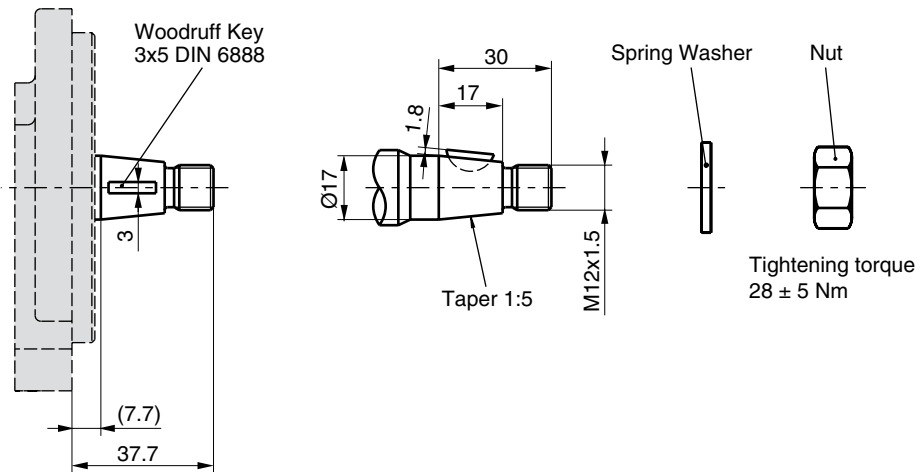

Code S2

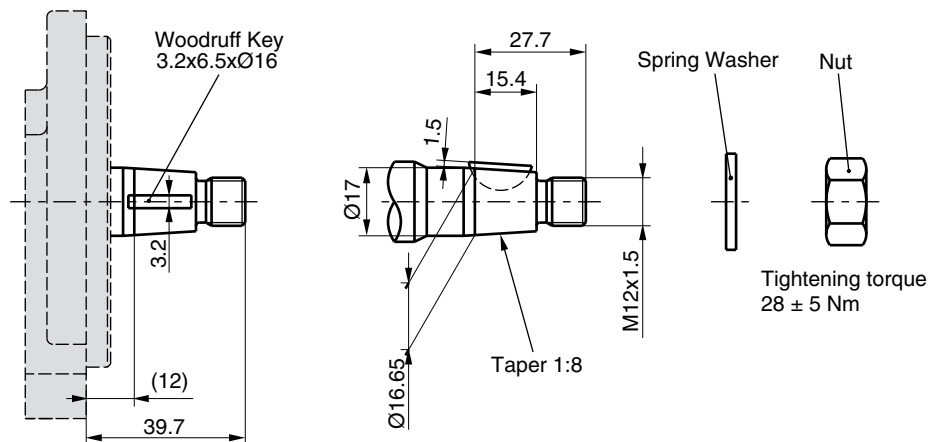

PGP/PGM 511 Drive Shaft

Code S8

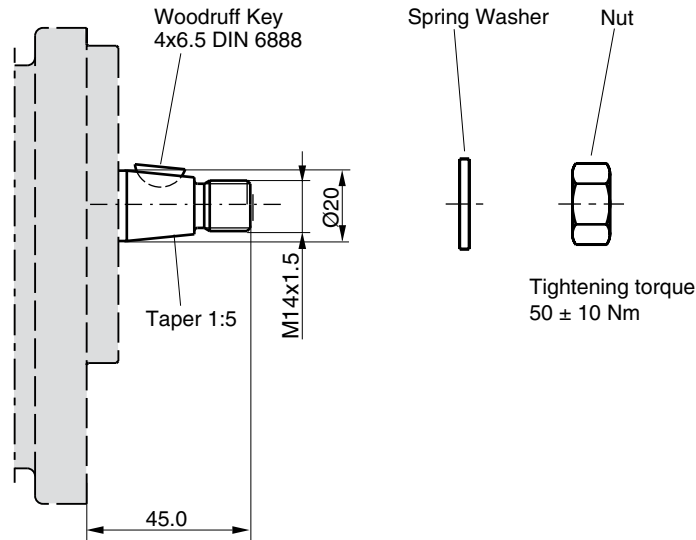

Code V5

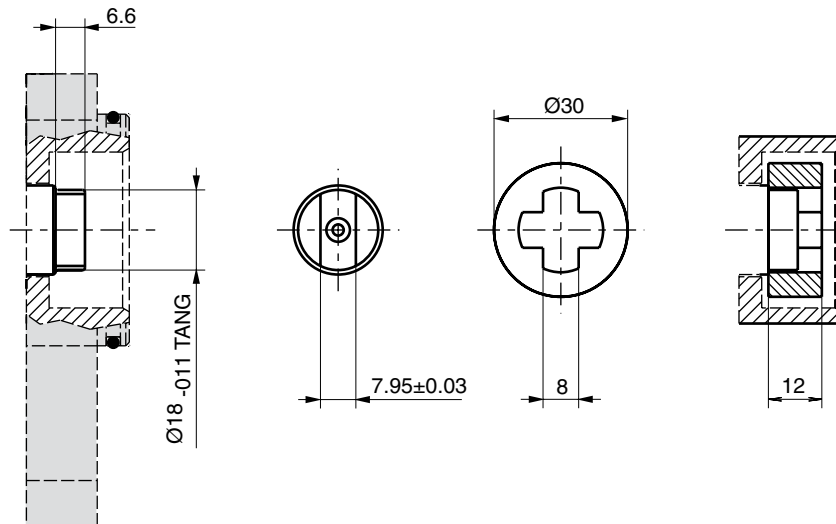

PGP/PGM 511 - Shaft Load Capacity

Code	Description	Torque Rating [Nm]
A1	9T, 16/32DP, 32L, SAE“A” spline	86
C1	11T, 16/32DP, 38.2L, SAE 19-4 spline	166
F5	B8x32x36 DIN ISO 14 (similar to DIN 5462) spline	166
K1	Ø15.88, 4.0 KEY, no thread, 32L, SAE“A” parallel	75
L6	Ø19.05, 4.8 KEY, no thread, 32L, SAE 19-1 parallel	145
S1	Ø17.0, 7.7L, 3.0 KEY, M12x1.5 taper 1:5	193
S2	Ø16.65, 12.0L, 3.2 KEY, M12x1.5 taper 1:8	198
S8	Ø20, 9.4L, 4.0 KEY, M14x1.5 taper 1:5	110
V5	8x6.5 short shaft tang drive	60
	Multiple pump connection shaft	110

$$\text{Torque [Nm]} = \frac{\text{Displacement [cm}^3\text{/rev]} \times \text{Pressure [bar]}}{57.2}$$